

SEQUENCE OF OPERATION

General: The constant volume 100% outside make up air handler with energy recovery shall be fully controlled by the BAS. Make up air handler control logic strategies shall include:

- Scheduled Occupancy: BAS shall determine the occupancy periods (occupied and unoccupied). The following details the common control aspects related to the scheduled occupancy.
 - Occupied Period: BAS shall energize the MA during all occupied periods. Note that the beginning of the occupancy period shall be set sufficiently before the actual start of occupancy to obtain the required building component of ventilation per IMC. "Normal" setpoints shall apply.
 - Unoccupied Period: If during the unoccupied period there is a request for occupancy override, the occupancy mode shall become active for an adjustable period. The unoccupied period and the pre-occupancy period will typically overlap.
- Sequenced Heating and Cooling: BAS shall control the heating and cooling coils as detailed.
- Freeze Safety: Upon operation of a freeze-stat the following sequence shall occur:
 - The unit fans shall be deenergized. Typically supply and exhaust fans where applicable shall be deenergized via a hardwired interlock, and an indication of the operation shall be displayed by the BAS.
 - All chilled water valves will be commanded to 100% open.
 - BAS shall enunciate appropriate alarm and remove and lock out the start command.
- Smoke Safety: Upon indication of smoke by a smoke detector, FAC shall deenergize the MA. Smoke detector shall notify the fire alarm system and BAS and shut down the fans.

Supply Fan Control: BAS shall control the starting and stopping of the supply fan as follows:

 - Start/Stop: BAS shall command the outside air damper open whenever the MA is "energized". Upon proof of the damper position the interlocked supply fan shall run continuously. The outside air damper shall close 4sec (adj.) after the supply fan stops.
 - Proof: BAS shall prove fan operation and use the status indication to accumulate runtime. Upon failure of the supply fan, BAS shall enunciate an alarm.

Exhaust Fan Control: BAS shall control the starting and stopping of the exhaust fan as follows:

 - Start/Stop: BAS shall command the exhaust air damper open whenever the MA is "energized". Upon proof of the damper position the interlocked exhaust fan shall run continuously. The exhaust air damper shall close 4sec (adj.) after the exhaust fan stops.
 - Proof: BAS shall prove fan operation and use the status indication to accumulate runtime. Upon failure of the exhaust fan, BAS shall enunciate an alarm.

Enthalpy Wheel Control: BAS shall control the starting and stopping of the enthalpy wheel as follows:

 - Whenever the unit is energized and the outside air dew point temperature is greater than 45F (adj.):
 - Enthalpy wheel shall operate at full speed if outside air enthalpy is greater than the sensible wheel exhaust air enthalpy.
 - Enthalpy wheel shall not operate if outside air enthalpy is less than the sensible wheel exhaust air enthalpy.
 - Whenever the unit is energized and the outside air dew point temperature is less than 45F (adj.):
 - The speed of the enthalpy wheel shall be modulated to maintain the supply air dew point temperature at 45F (adj.). The speed of the enthalpy wheel shall be increased upon a drop in supply air dew point temperature.
 - Periodic self cleaning: The enthalpy wheel shall run at 5% speed for 10sec every 4hrs the unit runs.
 - Frost protection: The enthalpy wheel shall run at 5% speed whenever
 - the outside air is less than 15F
 - OR the exhaust air is less than 20F.

Supply Air Temperature Setpoint: The supply air temperature setpoint shall be 55F (adj.).

Preheat Coil Control: BAS shall modulate the preheat coil valve and pump as follows:

 - The N.O. valve shall modulate per the higher of:
 - a PID loop to maintain a preheat air temperature at the supply air temperature setpoint minus 5F, whenever the unit is energized,
 - OR a proportional only loop maintaining a low limit of 40F preheat air temperature.

Preheat Pump Control: BAS shall control the starting and stopping of the preheat pump as follows:

 - Start/Stop: The preheat pump shall run continuously whenever the preheat valve is open or the outside air temperature is less than 45F (adj.).
 - Proof: BAS shall prove pump operation and use the status indication to accumulate runtime. Upon failure of the preheat pump, BAS shall enunciate an alarm.

Chilled Water Coil Control: BAS shall modulate the chilled water coil valve as follows:

 - Whenever the unit is energized and the outside air dew point temperature is greater than 45F (adj.):
 - The chilled water coil valve is modulated to maintain the cooling coil discharge air temperature at 45F (adj.).
 - Whenever the unit is energized and the outside air dew point temperature is less than 45F (adj.):
 - The chilled water coil valve is modulated to maintain the cooling coil discharge air temperature at the supply air temperature setpoint.

Sensible Wheel Control: BAS shall control the starting and stopping of the enthalpy wheel as follows:

 - Whenever the unit is energized the speed of the sensible wheel shall be modulated to maintain the supply air temperature setpoint.

Reheat Coil Control: BAS shall modulate the reheat coil valve as follows:

 - If the sensible wheel speed is at maximum and the supply air temperature is not being maintained at the supply air temperature setpoint, the reheat valve shall be modulated to maintain the supply air temperature at the supply air temperature setpoint while the sensible wheel remains at maximum speed.

Developed in Association with
Facility Dynamics
 ENGINEERING
 6700 Alexander Bell Drive - Suite 220
 Columbia, MD - 21046 - (410) 290-0800

UNIVERSITY of VIRGINIA
 FACILITIES MANAGEMENT
 HVAC CONTROLS STANDARDS

Eng	DMC
Drawn	DMC
Chkd	HJN
Appd	---
Issued	8/4/11
Job No.	10080
Scale	N/A
Proj Code	

STANDARD

MAKE UP AIR UNIT (SCHEMATIC)

09 OF 30 SHEET NUMBER

C-1.3a

DWG NUMBER

NOTES

- Provide BACnet interface to the control system for diagnostic point information. VSD rate of change (Acceleration/Deceleration) shall be programmed in to the VSD controller and not rely on BAS logic.
- Provide multiple freeze-stats as required to achieve 1ft. of linear element for each 1sq.ft. of coil face area. Preheat sensor shall be installed intertwined with freeze-stat to cover the exact same area. One set of contacts wired directly to drive safety input.

BILL OF MATERIAL

DESIG	QTY	MODEL NO.	DESCRIPTION
TS 1,4&5	3		Temp Sensor, Duct
TS 2,3,6&7	4		Temp Sensor, Duct (Averaging)
V1, V2, V3	3		Valve Actuators
SD 1 & 2	2		Smoke Detectors
FZ1	1		Freeze-stat 40F, DPDT
CS 1&2	2		Current Switch
M 1&2	2		Damper Actuators
LS 1&2	2		Damper End Switches
HS 1-3	3		Humidity Sensor, Duct

ELECTRIC LADDER DIAGRAMS

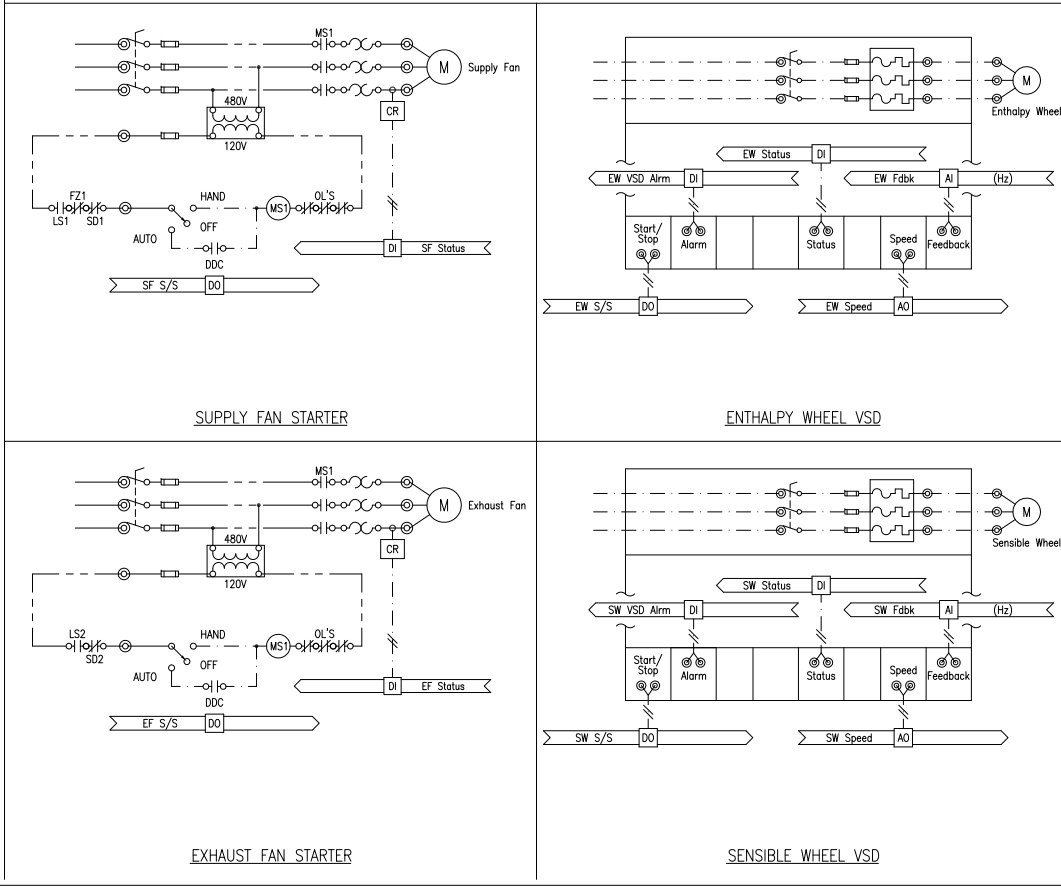

CONTROL SCHEMATIC